

MEGABLUE®



3 YEAR WARRANTY

PERFORMANCE

23 dba

MAX FLOW	MAX HEAD	MAX LIFT
50 L/ HOUR	20 METRES	7 METRES

The MEGABLUE® has a slimline, lightweight design and is whisper quiet, it also has the performance to overcome installation challenges and uses the BlueDiamond® revolutionary patented principle, making it inherently reliable. With the MEGABLUE® there's no cost penalty up front but big savings on installation and in service beyond.



UNIT
14-50 KW

SENSING OPTION

MEGABLUE® pump available with:

RESERVOIR	TEMPERATURE SENSOR	DRAINSTIK® SENSOR
X87-813	X87-814	X87-820

PERFORMANCE

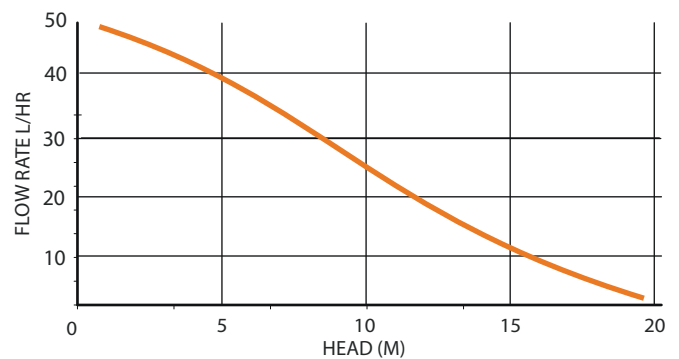

3 YEAR WARRANTY

Accredited with our own industry pioneering 3 year warranty. We have faith in our reliability and so should you.



BLUEDIAMOND® Pumps are the only manufacturer of patented Rotary Diaphragm (RD) and GyRok™ technology.

DISCHARGE PIPE RUN

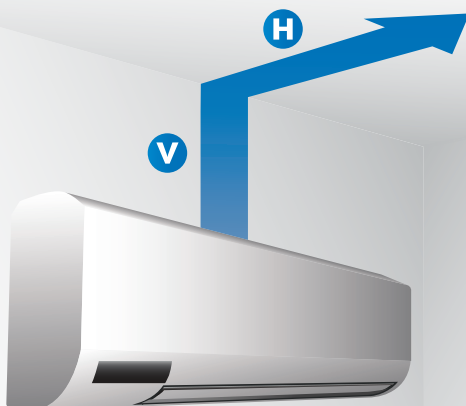

*50 KW MAX

DIMENSIONS (MM)

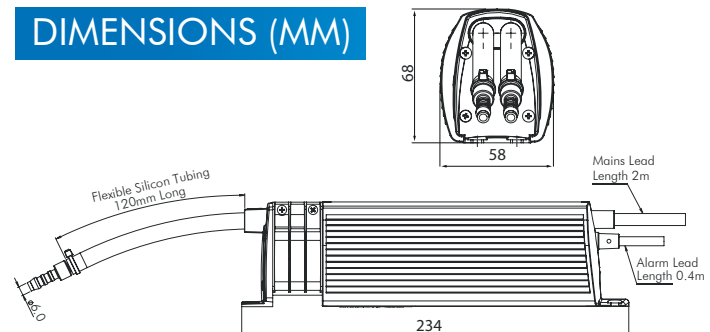

V (VERTICAL)	H (HORIZONTAL)
20 M	0 M
15 M	15 M
10 M	30 M
5 M	45 M
0 M	60 M

The MEGABLUE® can be mounted in any orientation up to 7m away from the air conditioning unit.